

Family Relationships and Parenting Practices: A Pathway to Adolescents' Collectivist and Individualist Values?

Ana Prioste, Isabel Narciso, Miguel M. Gonçalves & Cícero R. Pereira

Journal of Child and Family Studies

ISSN 1062-1024

J Child Fam Stud

DOI 10.1007/s10826-015-0129-3

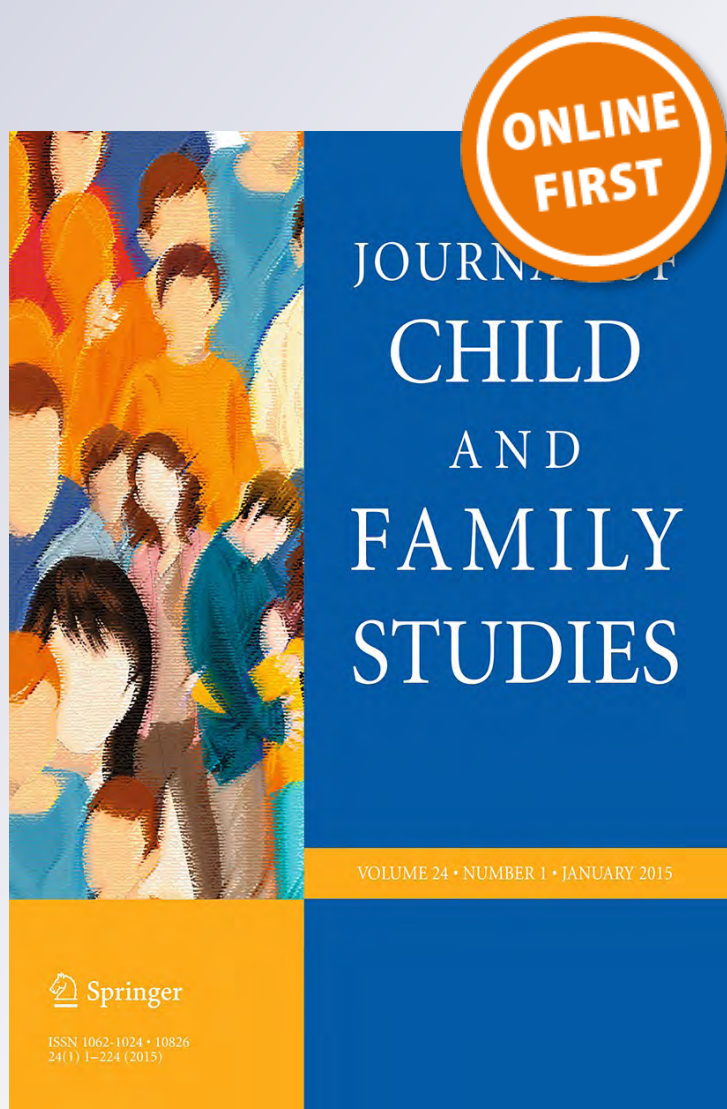

Your article is protected by copyright and all rights are held exclusively by Springer Science +Business Media New York. This e-offprint is for personal use only and shall not be self-archived in electronic repositories. If you wish to self-archive your article, please use the accepted manuscript version for posting on your own website. You may further deposit the accepted manuscript version in any repository, provided it is only made publicly available 12 months after official publication or later and provided acknowledgement is given to the original source of publication and a link is inserted to the published article on Springer's website. The link must be accompanied by the following text: "The final publication is available at link.springer.com".

Family Relationships and Parenting Practices: A Pathway to Adolescents' Collectivist and Individualist Values?

Ana Prioste · Isabel Narciso · Miguel M. Gonçalves ·
Cícero R. Pereira

© Springer Science+Business Media New York 2015

Abstract Adolescents' perceptions of parenting and family relationships are important variables for identifying mechanisms involved in how children acquire values and how these values are transmitted through families. In a sample of 515 adolescents, we investigated whether perceptions of the quality of parental practices would predict adolescents' collectivist and individualist values. We hypothesized that perceived quality of family relations would mediate the relationship between the quality of parental practices and collectivist values but not of individualist values. The results of structural equation modeling suggested that perception of the quality of parental practices predicted adolescents' both collectivist and individualist values. The predicted mediation effect was found for collectivist values, but not for individualist values. The results point to different functions of parenting and family relations on value acquisition. Implications for practice, such as the development and implementation of interventions to improve the formation of adolescents' values by enhancing the quality of parenting and family relationships are discussed.

Keywords Adolescence · Collectivist values · Individualist values · Parental practices · Family relations

Introduction

The contribution of family and parental variables to adolescents' value acquisition has been a subject of interest for the scientific community (Bengtson et al. 2002; Friedlmeier and Friedlmeier 2012; Grusec et al. 2000; Pinquart and Silbereisen 2004; Schwartz et al. 2010). A large body of studies points to family relational climate and parenting practices as operative mechanisms in the formation of children's values and the familial transmission of values (Bengtson et al. 2002; Grusec 2002; Pinquart and Silbereisen 2004; Roberts et al. 1999; Roest et al. 2009a; White and Matawie 2004; Yi et al. 2004). Positive parenting, which is characterized by parental practices embedded in affect, support and discipline focus, seems to be strongly associated with family relational climate, namely, cohesion, conflict management and expressiveness (Baldwin 1955; Kitzmann 2000; Kolak and Volling 2007; Persson et al. 2004; Stattin et al. 2011). Family relations play an essential role in value transmission, as families select and emphasize the values that better contribute to the maintenance of family identity (Cigoli and Scabini 2006; Trommsdorff 2009). The topic of familial transmission of values, namely the roles of parental practices and of family relations on adolescents' values, has not been sufficiently investigated (Roest et al. 2009a, b). This topic deserves additional investigation for several reasons, which are highlighted below.

First, the familial transmission of values is a relational, bidirectional and continuous process (Pinquart and Silbereisen 2004; Phalet and Schönplflug 2001; Roest et al.

A. Prioste (✉)
Faculdade de Psicologia da Universidade de Lisboa, Alameda da
Universidade, 1649-013 Lisbon, Portugal
e-mail: anaprioste@gmail.com

I. Narciso
Faculdade de Psicologia, Universidade de Lisboa, Lisbon,
Portugal

M. M. Gonçalves
Escola de Psicologia, Universidade do Minho, Braga, Portugal

C. R. Pereira
Instituto Ciências Sociais, Universidade de Lisboa, Lisbon,
Portugal

2009a), and it is important to map out the underlying mechanisms and variables that contribute to this ultimate outcome, i.e., adolescents' values. For example, family psychologists can benefit from mapping out these mechanisms and variables to develop and implement interventions to improve the formation of adolescents' values by enhancing the quality of parenting and family relationships. There currently is a lack of consensus in the literature about how values are transmitted through families, mostly due to different classes of values (individualist vs. collectivist) and methodological diversity (e.g., Barni et al. 2011; Boehnke 2001; Roest et al. 2009a, b; Rohan and Zanna 1996). Previous research has highlighted a number of parental and familial variables that can influence or mediate the formation and transmission of values, including the quality of the relationship between parents and children (Grusec et al. 2000); parenting styles (Grusec 2002; Pinquart and Silbereisen 2004); parental love and emotional support (Roberts et al. 1999); communication (Grusec and Goodnow 1994; White 2000) and parental consistency in messages about values over time (Knafo and Schwartz 2003); value similarities between fathers and mothers (Barni et al. 2011; Knafo and Schwartz 2003); and family cohesion and adaptability (Roest et al. 2009a; White and Matawie 2004; White 2000).

Second, collectivism and individualism have been investigated extensively in recent cross-cultural research (Oyserman et al. 2002; Tulviste and Gutman 2003), which has considered different cultures' general values orientation, or the priority or position of the self in relation to others (Singelis et al. 1995; Schwartz et al. 2010; Triandis 1995). Schwartz' theory of basic individual values proposes the order of the values around the circular motivation continuum (Schwartz 1992). In a recent study, Schwartz et al. (2012) suggested another determinant to order the values: the focus on personal versus social outcomes. In the present study, we organized Schwartz Values Survey's (SVS) values through the labels: collectivist values (CV) to refer to group-oriented or values focused on social outcomes; and individualist values (IV) to mean self-oriented values or values focused on personal outcomes. Research on parenting has also focused on the cultural meanings of different parenting styles in individualist and collectivist cultural groups, and relationships between parenting styles and children's well-being (e.g., Rudy and Grusec 2006). To our knowledge, however, no within-culture study has examined both collectivist and individualist values while focusing on parental and family influences that may contribute to these values.

Social tendencies regarding collectivist and individualist values might be reflected in the socialization of children, through the role of the self in relation to others (Brofenbrenner 1986; Trommsdorff 2012; Tulviste and Gutman

2003). At a macrosystemic level, then, we must consider that broad cultural values shape parental practices through parenting goals and beliefs (Darling and Steinberg 1993), which influence children's acquisition of values (Rudy and Grusec 2006; Rudy et al. 1999).

At a microsystemic level, the Value Acquisition Model (Grusec and Goodnow 1994) suggests that a child's successful value internalization—that is, accurate perception of the parental message and acceptance or rejection of the perceived message—is a result of effective parenting in which parental practices play a powerful role. Accurate perception will depend on children's attention at the parents' message and on the clarity and redundancy of the message (Grusec and Goodnow 1994; Knafo and Schwartz 2003). Acceptance or rejection seems to be a complex process that depends on several processes: (1) child's motivation for the message; (2) message perception as appropriate and as a facilitator of self-generated feelings; (3) consistency of the message, i.e., the coherence between verbally stated values and parents' behaviors; and (4) a supportive parent-child relationship with high levels of cohesion and low levels of conflict (Barni et al. 2011; Grusec and Goodnow 1994; Grusec et al. 2000; Knafo and Schwartz 2003; White and Matawie 2004).

Several studies have converged on the importance of nurturing, protection and parental responsiveness for the process of value acquisition and transmission (Grusec and Goodnow 1994; Grusec et al. 2000; Taris et al. 1998; Taris 2000). Although some studies suggest an association between authoritative parenting and the effectiveness of value internalization (e.g., Pinquart and Silbereisen 2004), cross-cultural research suggests that this generalization may be culture-specific (Rudy et al. 1999; Tulviste and Gutman 2003), linking microsystemic and macrosystemic levels. For example, in collectivist cultures it is important that children learn to inhibit the expression of their desires and needs, instead attending primarily to the needs of others (Grusec et al. 1997). In these groups, effective parenting may involve the promotion of interdependence and cooperation in children rather than autonomy—an outcome achieved through the use of more authoritarian parenting practices (Grusec et al. 1997; Rudy and Grusec 2006; Rudy et al. 1999; Tulviste and Gutman 2003). In individualist social groups, parents tend to endorse authoritative parenting and encourage the fulfillment of their child's own intentions, independence and creative behavior (Rudy et al. 1999; Tulviste and Gutman 2003).

Previous research has suggested that family emotional quality—a predictor of child behavior in and of itself (e.g., Pereira et al. 2009; Schoppe et al. 2001)—is a mediating variable of the effectiveness of value transmission (Grusec et al. 2000; Rudy and Grusec 2001). The quality of relationships among family members (parents, couple and

siblings) creates a family-level emotional climate or environment that identifies an intimate context within each nuclear family (Moos and Moos 1989). This literature suggests an association between a positive perception of family relationship quality—characterized by intra-family relationships that promote feelings of safety, acceptance and emotional support among its members (Negy and Snyder 2006)—and intergenerational continuity of values between parents and children (Bengtson et al. 2002; Taris et al. 1998; White 2000).

Existing models (e.g., Grusec and Goodnow 1994; White 2000; White and Matawie 2004) tend to explain the process of value acquisition on the basis of internalization, regardless of the classes of values (individualist vs. collectivist). However, several authors highlight relevant differences in this process, depending on different values (Barni et al. 2011; Boehnke 2001; Roest et al. 2009b). Therefore, two complementary perspectives regarding value transmission have been suggested. The salience perspective (Pinquart and Silbereisen 2004) proposes that values that are more salient for family members are more likely to be transmitted, whatever their class. In contrast, the evolutionary perspective (Schönplflug 2001) asserts that parents would be more likely to transmit collectivist than individualist values because the former serve the in-group, reinforcing family cohesion and cooperation. This perspective has been reinforced by studies in which stronger intergenerational similarities for CV were found between parents and adolescents (e.g., Friedlmeier and Trommsdorff 2011; Roest et al. 2009a, b; Schönplflug 2001). A large body of studies notes that beyond a family system's protective function, CV also have protective functions for individuals, such as promoting self-esteem and well-being (Ghazarian et al. 2008), and protecting against anxiety and depression and distress (Zhang et al. 2007). Schwartz et al. (2010) hypothesized that CV facilitate the development of supportive relationships and a greater connectivity to social systems (e.g., family) and encourage persons to be responsible for their behavior and its consequences on others.

Compared to other age groups, adolescents are more likely to prioritize more values focused on personal outcomes (Prioste et al. 2012; Sabatier and Lannegrand-Willems 2005), notwithstanding several studies suggesting that parents do not transmit IV to their children (Barni et al. 2011; Roest et al. 2009a). Individualist values (e.g., materialism, individual pleasure) might be mostly related to peer and media influences (Flouri 1999), which also supports the evolutionary perspective (Schönplflug 2001). Despite individualism's focus on the personal—goals, uniqueness, and control—and de-emphasis of the social (Triandis 1995), this orientation implies an ambivalent dynamic regarding relationships because individuals need

relationships and group memberships to attain self-relevant goals (Oyserman et al. 2002).

Based on the literature reviewed above, in the current study, we aim to analyze the influence of parental practices, including emotional support and rejection, on adolescents' collectivist and individualist values, as well as the mediating role of quality of family relations on this process. Because several studies (e.g., Grusec and Goodnow 1994; Grusec et al. 2000; Pinquart and Silbereisen 2004; Taris et al. 1998; Taris 2000) suggested the importance of supportive and non-rejecting parenting for the effectiveness of value acquisition, we expected that children's positive perceptions of parental practices would be a positive predictor of adolescents' both collectivist and individualist values. As IV might represent a threat to the in-group by reinforcing individual needs over family cohesion and cooperation, and because family relationships can act as a mechanism that selects CV as guidelines for living together (Schönplflug 2001), we expected that positive perceptions of family relations would mediate the acquisition of adolescents' CV but not of IV. In this way, we hypothesize that the perceived quality of family relationships is the mechanism by which CV (but not IV) are transmitted to children. In summary, we expected that more positive perceptions of parental practices would lead to increased perceptions of the quality of family relationships, which would in turn lead to an increase in the importance of CV as guiding principles of adolescents' lives.

Method

Participants

This sample comprised 515 Portuguese adolescents from intact families, i.e., from two parents' families, between 15 and 19 years of age ($M = 16.3$; $SD = 1.20$). Of the total sample, 271 (52.62 %) were females and 244 (47.38 %) were males. Most had medium educational level, between 10 and 12 years of education (86.8 %); never had significant psychological or psychiatric complaints (76.3 %) or serious physical health problems (84.5 %); and followed religious practices (62.9 %). Participants lived in several Portuguese geographic regions: 54 % in Lisboa and surrounding areas, 26 % in the center region, 17.1 % in the north region and 3.9 % in other regions of the country.

Procedures

Participants were selected from a larger sample of 780 participants belonging to intact, single parent or recomposed families who were participating in a broader study about intergenerational family (dis)similarities of values

and relationship patterns. For inclusion in the present study, participants were required to be adolescents, between 15 and 19 years of age, who were involved in intact families. Only one adolescent per family was included, so in families with more than one adolescent child, we decided to include the older child. A sample of 515 participants met the criteria for this study. Participants were recruited over a 2-year period, through a non-probabilistic sampling strategy. Using a snowball process, we recollected data from 19.4 % of the sample through informal contacts, 5.4 % through the collaboration of the Portuguese Association of Large Families (APFN), and 75.2 % at six schools in the Greater Lisbon region, Central region and North region of Portugal. The questionnaire packets were delivered personally to participants or were mailed in the case of large families. In both cases, one researcher, consistently for all participants, was available by e-mail and telephone to assist adolescents in completing the questionnaires if questions arose. Questionnaires which were delivered personally were returned to the researchers in person (e.g., informal contacts and school setting); questionnaires which were mailed (e.g., large families) were returned to the researchers by mail. All participants were informed about the main objectives of the research through a written document. The voluntary nature of their participation was also explained, and the participants were assured of confidentiality. An informed consent document had previously been signed by all participants. At schools, data collection was conducted according to the guidelines of the national office of “Monitoring of Surveys in Schools”, and all school directors formally authorized the study. At schools, the protocol was applied in groups, voluntarily, with informed consent provided by all participants and parents. Adolescents who completed questionnaire packets in groups (e.g., school setting) were advised to complete them independently of each other. In school setting, one researcher, consistent for all participants, was available to assist adolescents in completing the questionnaires if questions arose.

Measures

Values Assessment

Adolescents reported on their own values using the Personal Values Questionnaire (SVS, Schwartz, 1992; translation and adaptation by Menezes and Campos 1991 and Prioste et al. 2012). The SVS includes a single list of 63 values as guiding principles of life, rated on a 1–6 Likert scale (Not important to Fundamental importance). The SVS assesses eight dimensions—types of values—organized on two classes of values—individualist and collectivist values. The collectivist class is composed of relational (R), traditionalism (T),

social concern (SC) and spirituality (S) types of values, and refers to the importance of interdependence values, i.e., emphasizing values about one’s connectedness with others. collectivist class includes items such as ‘Family (importance of family priority in life course)’ and ‘Generosity (valuation of altruist actions on behalf of others)’. The individualist class is composed of social power (SP), adventure (A), personal balance (PB) and personal achievement (PA) types of values, and refers to the importance of values that emphasize one’s disconnectedness with others. Individualist class includes items such as ‘Personal Independence (valuation of self-sufficiency and autonomy)’ and ‘Pleasure (satisfaction of desires)’.

In a previous study with a sample of Portuguese family triads (Prioste 2014), collectivist and individualist classes showed good internal consistency ($\alpha = .88$ for collectivist and $\alpha = .90$ for individualist). In the current study, we also found good internal consistency for collectivist ($\alpha = .90$) and individualist classes ($\alpha = .86$).

Paternal and Maternal Rearing Practices Quality Assessment

Adolescents completed the Eгна Minnen av Barndoms Uppfostran—My memories (EMBU-M; Perris et al. 1980; adapted for the Portuguese population by M. C. Canavarro 1996), which probes adolescents’ perceptions of their parents’ parenting styles. The EMBU-M includes 23 items which participants rate separately for mother and father on a four-point Likert scale ranging from 1 (No, never) to 4 (Yes, most of the time). This measure assesses three dimensions of parenting styles: emotional support, which includes items such as ‘My parents praise me’, rejection, which contains items such as ‘My parents criticize me in front of other people’, and overprotection. In this study, we used only mothers’ and fathers’ emotional support and mothers’ and fathers’ rejection dimensions for calculated adolescents’ perceptions of the quality of mothers’ parental practices (PQPPM) and of fathers’ parental practices (PQPPF) because we found an unacceptable value of internal consistency for the overprotection dimension.

Canavarro (1996) found weak values of internal consistency for the total score. In the present study, we found satisfactory values of internal consistency for emotional support ($\alpha = .78$ for adolescents’ perceptions about mothers; $\alpha = .77$ for adolescents’ perceptions about fathers) and rejection ($\alpha = .77$ for adolescents’ perceptions about mothers; $\alpha = .74$ for adolescents’ perceptions about fathers).

Family Relationship Quality

Adolescents completed the relational dimension of the Family Environment Scale (Moos and Moos 1989;

Portuguese adaptation: Matos and Fontaine 1992), which assessed perceptions of the quality of family relationships. The relational dimension includes 27 items and assesses three dimensions of family relationship quality—cohesion, expressivity and conflict—rated on a scale ranging from 1 (Totally disagree) to 6 (Totally agree).

In the Family Environment Scale Portuguese validation study with a sample of children and adolescents, Santos and Fontaine (1995) found two factors for the complete scale with good internal consistency: centripetal families ($\alpha = .85$) and centrifugal families ($\alpha = .70$). In the current study, we performed an exploratory factor analysis on the relational dimension of the Family Environment Scale using the principal-axis factor method with oblique rotation. We found two factors: cohesion, with 14 items ($\alpha = .89$), and conflict, with 9 items ($\alpha = .77$), that together explained 37.48 % of the total variance. Cohesion includes items such as 'We have lots of time and attention to each other'. Conflict comprises items such as 'In my family we are angry often'.

Data Analyses

We tested the proposed model with a set of structural equation models with latent variables. We used a variance-covariance matrix of the items with pairwise deletion for missing data, and all parameters were estimated using the maximum likelihood algorithm with AMOS 19. To address our aims, we specified two models. In the first estimated model (see Fig. 1), which included eight latent variables, the relationship between adolescents' perceptions of parental practices' quality and CV was mediated by the perceived family relationship quality. In the second estimated model (see Fig. 2), we specified the perception of family relationship quality as a mediating variable between parental practices' quality and IV. In both models, the quality of parental practices (PQPP) was a second-order latent variable measured by adolescents' PQPPF and PQPPM. PQPPF was measured by fathers' rejection (FR) and fathers' emotional support (FES), while PQPPM was measured by mothers' rejection (MR) and mothers' emotional support (MES). Similarly, the perceived family relationship quality was a second-order latent variable measured by cohesion (C) and absence of conflict (AC). Our dependent variables were also specified as second-order latent variables measured by multi-item parcels of the four dimensions of the SVS. Specifically, CV was measured by R, T, SC and S, and IV was measured by SP, PB, A and PA. We used multi-item parcels to specify these latent variables to simplify the model and reduce the number of paths estimated (see Little et al. 2002). To guarantee the statistical identification of the models, the factorial loadings for one of the indicators of each latent variable was constrained at 1.00.

Results

We started by analyzing the perception of parental practices' quality as a predictor of adolescents' CV. The estimated parameters showed that the perception of parental practices' quality was significantly related to the dependent variable ($\beta = .18, p < .01$), and the fit of the model to the data was very good ($\chi^2_{71} = 189.27, p < .001$; CFI = .960, GFI = .949, AGFI = .925, RMSEA = .057), explaining 7 % of the variance in adolescents' CV. We then analyzed the perception of parental practices' quality as a predictor of adolescents' IV. The estimated parameters showed that it significantly predicted the dependent variable ($\beta = .27, p < .001$), and the fit of the model to the data was good ($\chi^2_{69} = 226.14, p < .001$; CFI = .940, GFI = .941, AGFI = .910, RMSEA = .067), explaining 3 % of the variance in adolescents' IV.

We then tested the hypothesis that the effects of the predictors (perceptions of parental practices' quality) on adolescents' collectivist (but not individualist) values would be mediated by perceived family relationship quality. We specified a model in which family relationship quality mediated the effects of the perception of parental practices' quality on adolescents' CV (see Fig. 1). The results indicated the presence of a mediating effect, such that increased perceptions of positive parental practices (more emotional support and less rejection) predicted increased perceptions of positive family relationships (more cohesion and less conflict), leading to an increase in the importance of CV as guiding principles of their lives. The mediation effect was reliable according to the Sobel test (Sobel = 5.26, $p < .001$). Importantly, the model showed an adequate fit to the data ($\chi^2_{161} = 460.42, p < .001$; CFI = .937, GFI = .915, AGFI = .890, RMSEA = .060), while explaining 14 % of the total variance in adolescents' CV, which was an improvement over the first model.

We also specified a model in which family relationship quality mediated the effects of the perception of parental practices' quality on adolescents' IV (see Fig. 2). Results indicated no mediating effect of family relationship quality in the relationship between perceived parental practices and adolescents' IV according to the Sobel test (Sobel = $-.05$, ns.). Nevertheless, the model showed an adequate fit to the data ($\chi^2_{159} = 463.44, p < .001$; CFI = .931, GFI = .916, AGFI = .890, RMSEA = .061), while explaining 3 % of the total variance in adolescents' IV.

Discussion

This study investigated whether perceived quality of parental practices would predict collectivist and individualist values

Fig. 1 Standardized maximum likelihood coefficients for the structural equation model depicting the relationship between perception of parental practices' quality and collectivist values, mediated by perceived family relationship's quality. *PQPPM* perception of mother's parental practices quality, *PQPPF* perception of father's parental practices quality, *PQFR* perception of family relationships' quality, *C* cohesion, *AC* absence of conflicts, *CV* collectivist values, *R* relational, *T* traditionalism, *SC* social concern, *S* spirituality. *Solid lines* represent significant coefficients ($p < .05$) and *dashed lines* represent non-significant coefficients

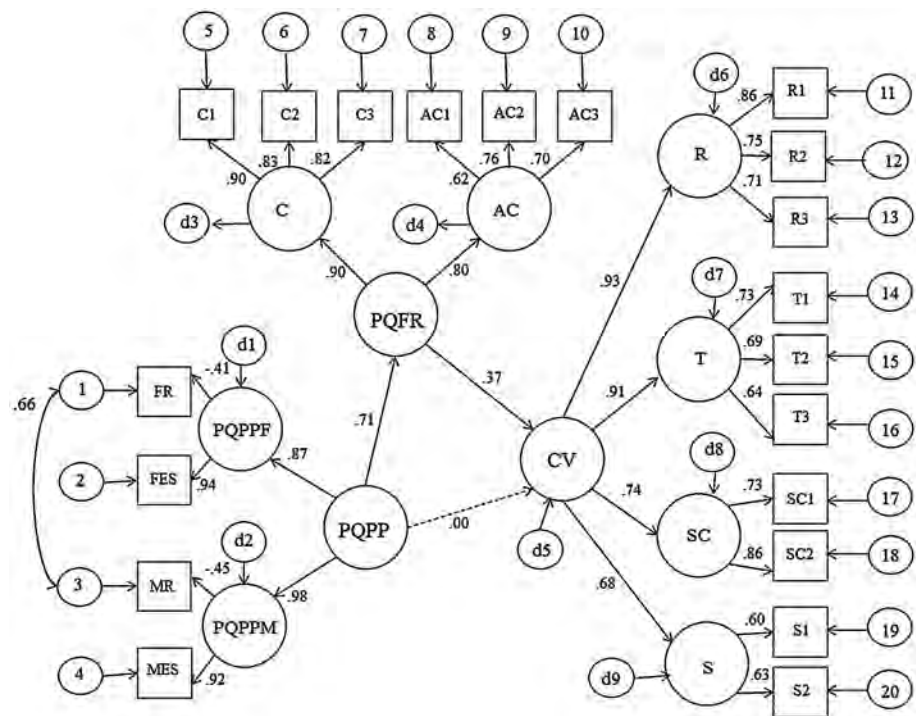
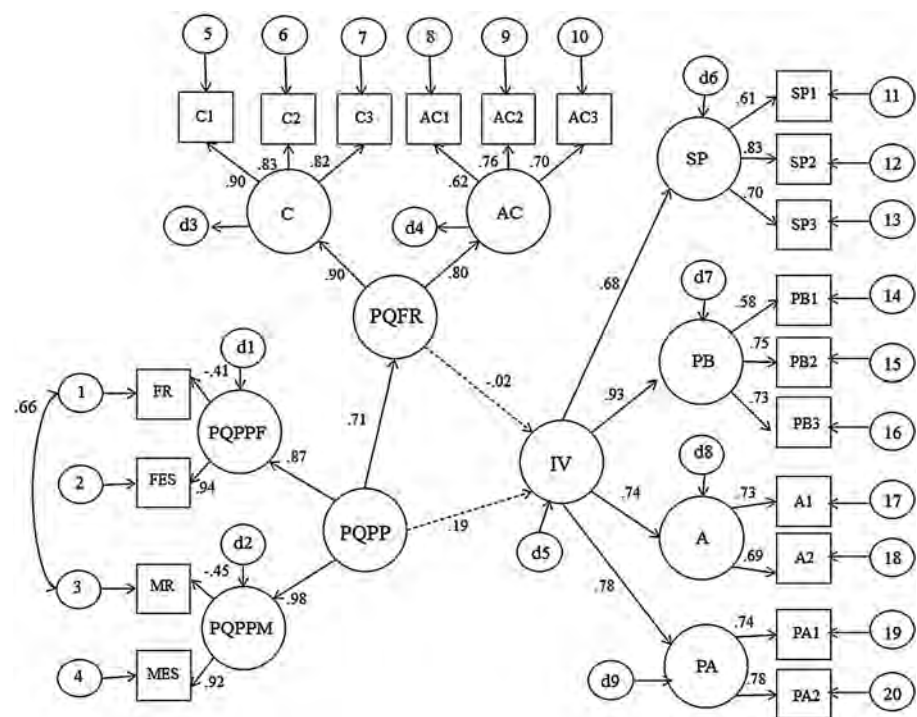

Fig. 2 Standardized maximum likelihood coefficients for the structural equation model depicting the relationship between perception of parental practices' quality and individualist values, mediated by perceived family relationship's quality. *PQPPM* perception of mother's parental practices quality, *PQPPF* perception of father's parental practices quality, *PQFR* perception of family relationships' quality, *C* cohesion, *AC* absence of conflict, *IV* individualist values, *SP* social power, *PB* personal balance, *A* adventure, *PA* personal achievement. *Solid lines* represent significant coefficients ($p < .05$) and *dashed lines* represent non-significant coefficients



and whether family relationship quality would mediate the relationship between quality of parental practices and collectivist and individualist values. Our findings support our hypothesis: a positive perception of parental practices was a significant predictor of adolescents' collectivist and

individualist values. These results are consistent with studies and models that emphasize the importance of supporting and non-rejecting parenting for the effectiveness of value acquisition (Grusec and Goodnow 1994; Grusec et al. 2000; Pinquart and Silbereisen 2004; Taris et al. 1998; Taris 2000).

These results could also highlight the role played by macrocontext on parental practices in the facilitation of children's adaptation to social demands (Rudy and Grusec 2006; Rudy et al. 1999). Although Portugal has been characterized as a collectivist culture (Hofstede 1980; House et al. 2002), other authors (e.g., Galinha et al. 2012) suggested that Portugal should be in between the most and the least individualistic countries. In line with this, some studies with Portuguese samples (e.g., Ramos 2006) suggested that, within the Portuguese culture, CV could be more relevant as guiding principles; on the other hand, a recent Portuguese study pointed to an increasing of individualist values' indicators over the last 10 years (Carvalho 2013). Therefore, effective Portuguese parenting could involve the promotion of "interdependence" in children, simultaneously emphasizing collectivist and individualist values. Furthermore, "interdependence" promotion and, consequently, the balance between collectivist and individualist values can be purposes of parenting from parents who are concerned about the children's well-being.

During adolescence, furthermore, parenting goals and beliefs may favor both collectivist and individualist values to support children's needs as they grow up—namely, the maintenance of sense of connection with others and the possibility to explore centrifugal pathways from family by searching for autonomy and developing their own identities. Ultimately, it is possible that this result can also exemplify the individualist ambivalence dynamic regarding relations: adolescents need to learn individualist behaviors and their meanings and to attain self-relevant goals (Oyserman et al. 2002).

Our hypothesis of a significant mediating effect of family relationship quality perception was also supported: positive perceptions of family relationship quality mediated the relationship between perception of parental practices' quality and adolescents' CV (but not IV). These results support the Schönflug (2001) perspective, according to which values that emphasize, preserve and protect family connection and collaboration are more likely to be transmitted by families. These results also highlight the different features and functions of parental practices and family relationships on children's education and development. We hypothesize that the family relationships can be a "funnel" that selects which values are transmitted through relationship pattern modeling. This mechanism can indicate that, beyond the representation of basic needs and motivations, CV are anchored in family identity and in the ideological positions derived from this identity (see Pereira et al. 2005).

The current data suggest that within a given culture, different processes may better explain the acquisition of values: the pathway to CV seems to be learned, lived and co-built within family, but the pathway to IV can be better

understood through extra-familial agents (e.g., peers, media; see Flouri 1999). This result can be understood in terms of adolescents' developmental tasks, namely, differentiation from family and identity formation. These results also provide support for the theory of values organization (Schwartz 1992, 1994): the adherence to values is motivated by the wish to satisfy different needs (biological, stability of social relationships, and well-being and survival). This theory also states that different motivations such as self-interest and PA cannot be satisfied by the same source of values. The need for stability of social relationships or maintenance of the status quo (Pereira et al. 2005) can be provided by the family, but the needs focused in self are encouraged by other social systems.

Implications for Research and Practice

This study has implications for the literature on parenting, given its emphasis on the impact of adolescents' perceptions of maternal and paternal rearing practices on the acquisition of values. Our results suggest that adolescents can perceive the complementary roles of mothers' and fathers' parenting in their growth, proposing an expansion of the "restricted" role often attributed to fathers' parenting. Furthermore, the data suggest that perceptions of parenting can be a source of both collectivist and IV, which can have implications for the study of values.

Moreover, this work highlights the importance of relationship perceptions on values, showing that family and parents can be sources of values, particularly CV, in adolescence. With regard to the perception of relationships, our findings have implications for the field of family psychology and intergenerational transmission because they underscore the different functions of parenting practices and family relation qualities on adolescents' acquisition of values. Parental practices are perceived as influencing the acquisition of both collectivist and individualist values, allowing adolescents to better adapt to social demands. The family relationship can act as a "funnel" that protects family identity and cohesion, maintaining the status quo. In this line, our findings can potentially guide family psychologists and therapists in the development and the implementation of specific interventions to work on family mythology and adolescents' personal values by enhancing the quality of parenting and family relationships.

Thus, with regard to the sources of IV, our findings contribute to the field of values by proposing new avenues of research: Where do adolescents search for IV? Do specific systems, such as the peer group, have a central role as catalyzers of IV? Is the peer group identity dominated only by individualism? Or are IV instead potentiated by the relationship between systems (e.g., mesosystem, or the relationship between family and peers)?

Underlying all of these questions or suppositions is evidence that the family cannot be the source of IV, delegating to other human systems the power to transmit these values. This evidence and its consequences should be taken into account by social policies in order to simultaneously stimulate and protect the centrifugal pathway of adolescents from family, thus encouraging identity exploration and individual and familial well-being.

Limitations and Future Studies

Although the present study may contribute to the knowledge on intergenerational family transmission, parenting, and values, it has several limitations that must be underlined: (1) the sampling was selected through a non-probabilistic sampling strategy, and results cannot be generalized to the entire Portuguese population; (2) only one self-report measure was used to assess values as guiding principles of life, so it is unclear whether the findings can be generalized to other measures; (3) although the Personal Values Questionnaire included explicit explanations of each value, this measure requires a high level of abstract reasoning that could be less appropriate for younger adolescents (Bilsky 2009); (4) this was a cross-sectional study, so we cannot infer causal associations between the variables analyzed.

Our results should be carefully examined in future work with more complex methodological designs and data analysis procedures, particularly with longitudinal studies, mixed methodologies and diversified measures. Future studies should address other factors that could be explored and tested in revised models to enhance the models' fit and increase the explained variance in acquisition of CV (e.g., children' sex, family routines and rituals and number and age of siblings). Future studies should also explore the contributions of family-of-origin, nuclear family and parental variables on values across different developmental stages (e.g., adulthood) to better understand the extensiveness of family and parental influences on values.

Acknowledgments This work was supported by the Ph.D. Grant of the first author (SFRH/BD/62182/2009), financed by Technology and Science Foundation (FCT).

References

- Baldwin, A. L. (1955). *Behavior and development in childhood*. New York: Dryden Press.
- Barni, D., Ranieri, S., Scabini, E., & Rosnati, R. (2011). Value transmission in the family: Do adolescents accept the values their parents want to transmit? *Journal of Moral Education*, 40, 105–121. doi:10.1080/03057240.2011.553797.
- Bengtson, V., Biblarz, T., & Roberts, R. (2002). *How families still matter: A longitudinal study of youth in two generations*. Cambridge: University Press.
- Bilsky, W. (2009). A estrutura de valores: Sua estabilidade para além de instrumentos, teorias, idades e culturas [The structure of values: Its stability across instruments, theories, ages, and cultures]. *RAM – Revista de Administração Mackenzie*, 10, 12–33.
- Boehnke, K. (2001). Parent-offspring value transmission in a societal context: Suggestions for an utopian research design—With empirical underpinnings. *Journal of Cross-Cultural Psychology*, 32, 241–255.
- Brofenbrenner, U. (1986). Ecology of the family as a context for human development: Research perspectives. *Developmental Psychology*, 22, 723–742.
- Canavarro, M. C. (1996). Avaliação das práticas educativas através do EMBU: Estudos Psicométricos [Assessment of educational practices through the EMBU: Psychometric studies]. *Psicologica*, 16, 5–18.
- Carvalho, L. X. (2013). *Literacia social: Os valores como fundamento de competência* [Social literacy: Values as a foundation of competence]. Tese de Doutoramento apresentada à Universidade Católica Portuguesa, Porto (manuscrito não publicado) (Unpublished manuscript).
- Cigoli, V., & Scabini, E. (2006). *Family identity: Ties, symbols, and transitions*. New Jersey: Lawrence Erlbaum Associates.
- Darling, N., & Steinberg, L. (1993). Parenting style as context: An integrative model. *Psychological Bulletin*, 113, 487–496.
- Flouri, E. (1999). An integrated model of consumer materialism: Can economic socialization and maternal values predict materialistic attitudes in adolescents? *Journal of Socio-Economics*, 28, 707–724.
- Friedlmeier, M., & Friedlmeier, W. (2012). Relative contribution of mothers and fathers to adolescents' values in Romanian families. *Cognition, Brain, Behavior: An Interdisciplinary Journal*, 16, 239–264.
- Friedlmeier, M., & Trommsdorff, G. (2011). Are mothers–child similarities in value orientations related to mothers' parenting? A comparative study of American and Romanian mothers and their adolescent children. *European Journal of Developmental Psychology*, 8, 661–680. doi:10.1080/17405629.2011.590649.
- Galinha, I. C., Oishi, S., Pereira, C., Wirtz, D., & Esteves, F. (2012). The role of personality traits, attachment style, and satisfaction with relationships in the subjective well-being of Americans, Portuguese, and Mozambicans. *Journal of Cross-Cultural Psychology*, 44, 416–437.
- Ghazarian, S. R., Supple, A. J., & Plunkett, S. W. (2008). Familism as a predictor of parent-adolescent relationships and developmental outcomes for adolescents in Armenian American immigrant families. *Journal of Child and Family Studies*, 17, 599–613. doi:10.1007/s10826-007-9177-7.
- Grusec, J. E. (2002). Parenting socialization and children's acquisition of values. In Bornstein, M. H. (Ed.), *Handbook of Parenting* (2nd ed., Vol. 5), Practical issues in parenting (pp. 143–167). Mahwah: Erlbaum Associates.
- Grusec, J. E., & Goodnow, J. J. (1994). Impact of parental discipline methods on the child's internalization of values: A reconceptualization of current points of view. *Development Psychology*, 30, 4–19. doi:10.1037/0012-1649.30.1.4.
- Grusec, J., Goodnow, J., & Kuczynski, L. (2000). New directions in analyzes of parenting contributions to children's acquisition of values. *Child Development*, 71, 205–211. doi:10.1111/1467-8624.00135.
- Grusec, J. E., Rudy, D., & Martini, T. (1997). Parenting cognitions and child outcomes: An overview and implications for children's internalization of values. In J. E. Grusec & L. Kuczynski (Eds.), *Parenting and children's internalization of values: A handbook of contemporary theory* (pp. 259–282). New York: Wiley.

- Hofstede, G. (1980). *Culture's consequences: International differences in work related values*. Beverly Hill: Sage.
- House, R., Javidan, M., Hanges, P., & Dorfman, P. (2002). Understanding cultures and implicit leadership theories across the globe: An introduction to Project GLOBE. *Journal of World Business, 37*, 3–10.
- Kitzmann, K. M. (2000). Effects of marital conflict on subsequent triadic family interactions and parenting. *Developmental Psychology, 36*, 3–13.
- Knafo, A., & Schwartz, S. H. (2003). Parenting and adolescents' accuracy in perceiving parental values. *Child Development, 74*, 595–611. doi:10.1111/1467-8624.7402018.
- Kolak, A. M., & Volling, B. L. (2007). Parental expressiveness as a moderator of coparenting and marital relationship quality. *Family Relations, 56*, 467–478.
- Little, T. D., Cunningham, W. A., Shahar, G., & Widaman, K. F. (2002). To parcel or not to parcel: Exploring the question and weighing the merits. *Structural Equation Modeling, 9*, 151–173.
- Matos, P. M., & Fontaine, A. M. (1992). *Family Environment Scale—FES. Adaptação portuguesa. Manuscrito não publicado [Family Environment Scale—FES. Portuguese adaptation. Unpublished manuscript]*. Faculdade de Psicologia e de Ciências da Educação da Universidade do Porto.
- Menezes, J., & Campos, B. P. (1991). Estrutura dos valores: Estudo transversal [Structure of values: Cross-sectional study]. *Psicologica, 6*, 129–147.
- Moos, R. H., & Moos, B. S. (1989). *Family environment scale manual*. Palo Alto, CA: Journal of Consulting and Clinical Psychologists Press.
- Negy, C., & Snyder, D. K. (2006). Assessing family-of-origin functioning in Mexican American adults: Retrospective application of the family environment scale. *Assessment, 13*, 396–405. doi:10.1177/1073191106289809.
- Oyserman, D., Coon, H. M., & Kemmelmeier, M. (2002). Rethinking individualism and collectivism: Evaluation of theoretical assumptions and meta-analyses. *Psychological Bulletin, 128*, 3–72. doi:10.1037/0033-2909.128.1.3.
- Pereira, C., Camino, L., & Costa, J. B. (2005). Um estudo sobre a integração dos níveis de análise dos sistemas de valores [A study about the integration of the value systems' levels of analysis]. *Psicologia: Reflexão e Crítica, 18*, 16–25. doi:10.1590/S0102-79722005000100004.
- Pereira, A. I., Canavarro, C., Cardoso, M. F., & Mendonça, D. (2009). Patterns of parental rearing styles and child behaviour problems among Portuguese school-aged children. *Journal of Child and Family Studies, 18*, 454–464. doi:10.1007/s10826-008-9249-3.
- Perris, C., Jacobsson, L., Lindström, H., Von Knorring, L., & Perris, H. (1980). Development of a new inventory for assessing memories of parental rearing behaviour. *Acta Psychiatrica Scandinavica, 61*, 265–274.
- Persson, S., Stattin, H., & Kerr, M. (2004). Adolescents' conceptions of family democracy: Does their own behavior play a role? *The European Journal of Developmental Psychology, 1*, 317–330. doi:10.1080/17405620444000238.
- Phalet, K., & Schönplflug, U. (2001). Intergenerational transmission in Turkish immigrant families: Parent collectivism, achievement values and gender differences. *Journal of Comparative Family Studies, 32*, 489–504.
- Pinquart, M., & Silbereisen, R. K. (2004). Transmission of values from adolescents to their parents: The role of value content and authoritative parenting. *Adolescence, 153*, 83–100.
- Prioste, A., Narciso, I., & Gonçalves, M. (2012). Questionário de Valores Pessoais Readaptado: Processo de desenvolvimento e contributos iniciais para a validação [Personal Values Questionnaire readapted: Development process and initial contributions to the validation]. *Revista Iberoamericana de Diagnóstico y Evaluación Psicológica, 34*, 175–199.
- Prioste, A. (2014). *Values and educative patterns: Maps of intergenerational transmission*. PhD Dissertation, Faculdade de Psicologia da Universidade de Lisboa (Unpublished manuscript).
- Ramos, A. (2006). Social values dynamics and socio-economic development. *Portuguese Journal of Social Science, 5*, 35–64. doi:10.1386/pjss.5.1.35/1.
- Roberts, R. E., Bengtson, V. L., & Biblarz, T. J. (1999). The social psychology of values: Effects of individual development, social change, and family transmission over the life span. In C. D. Ryff & V. W. Marshall (Eds.), *The self and society in aging processes* (pp. 453–482). New York: Springer.
- Roest, A. M., Dubas, J. S., & Gerris, J. R. (2009a). Value transmission between fathers, mothers, and adolescent and emerging adult children: The role of the family climate. *Journal of Family Psychology, 23*, 146–155. doi:10.1037/a0015075.
- Roest, A. M., Dubas, J. S., Gerris, J. R., & Engels, R. C. (2009b). Value similarities among fathers, mothers and adolescents and the role of a cultural stereotype: Different measurement strategies reconsidered. *Journal of Research on Adolescence, 19*, 812–833.
- Rohan, M. J., & Zanna, M. P. (1996). Value transmission in families. In C. Seligman, J. M. Olson, & M. P. Zanna (Eds.), *The psychology of values: The Ontario symposium* (Vol. 8, pp. 253–276). Hillsdale: Erlbaum.
- Rudy, D., & Grusec, J. E. (2001). Correlates of authoritarian parenting in individualist and collectivist cultures and implications for understanding the transmission of values. *Journal of Cross-Cultural Psychology, 32*, 202–212. doi:10.1177/0022022101032002007.
- Rudy, D., & Grusec, J. E. (2006). Authoritarian parenting in individualist and collectivist groups: Associations with maternal emotion and cognition and children's self-esteem. *Journal of Family Psychology, 20*, 68–78. doi:10.1037/0893-3200.20.1.68.
- Rudy, D., Grusec, J. E., & Wolfe, J. (1999). Implication of cross-cultural findings for a theory of family socialization. *Journal of Moral Education, 28*, 299–310. doi:10.1080/03057249910303098.
- Sabatier, C., & Lannegrand-Willems, L. (2005). Transmission of family values and attachment: A French three-generation study. *Applied Psychology: An International Review, 54*, 378–395. doi:10.1111/j.1464-0597.2005.00216.x.
- Santos, M., & Fontaine, A. M. (1995). Avaliação do ambiente familiar por crianças e pré-adolescentes: Alguns aspectos da adaptação da FES [Children and adolescents assessment of the family environment: Features of the adaptation of the FES]. In L. S. Almeida & I. S. Ribeiro (Eds.), *Avaliação Psicológica: Formas e Contextos* (pp. 421–430). Braga: APPORT.
- Schönplflug, U. (2001). Intergenerational transmission of values: The role of transmission belts. *Journal of Cross-Cultural Psychology, 32*, 174–185.
- Schoppe, S. J., Mangelsdorf, S. C., & Frosch, C. A. (2001). Coparenting, family process, and family structure: Implications for preschoolers' externalizing behavior problems. *Journal of Family Psychology, 15*, 526–545. doi:10.1037/0893-3200.15.3.526.
- Schwartz, S. H. (1992). Universals in the content and structure of values: Theory and empirical tests in 20 countries. In M. Zanna (Ed.), *Advances in experimental social psychology* (Vol. 25, pp. 1–65). New York: Academic Press.
- Schwartz, S. H. (1994). Are there universal aspects in the content and structure of values? *Journal of Social Issues, 50*, 19–45. doi:10.1111/j.1540-4560.1994.tb01196.x.
- Schwartz, S. H., Cieciuch, J., Vecchione, M., Davidov, E., Fischer, R., Beielein, C., et al. (2012). Redefining the theory of basic

- individual values. *Journal of Personality and Social Psychology*, 103, 663–688. doi:[10.1037/a0029393](https://doi.org/10.1037/a0029393).
- Schwartz, S. J., Weisskirch, R. S., Hurley, E. A., Zamboanga, B. L., Park, I. J., Su, Y. K., et al. (2010). Communalism, familism, and filial piety: Are they bird of collectivist feather? *Cultural Diversity and Ethnic Minority Psychology*, 16, 548–560. doi:[10.1037/a0021370](https://doi.org/10.1037/a0021370).
- Singelis, T. M., Triandis, H. C., Bhawuk, D., & Gelfand, M. J. (1995). Horizontal and vertical dimensions of individualism and collectivism: A theoretical and measurement refinement. *Cross-Cultural Research*, 29, 240–275.
- Stattin, H., Persson, S., Burk, W. J., & Kerr, M. (2011). Adolescents' perceptions of the democratic functioning in their families. *European Psychologist*, 16, 32–42. doi:[10.1027/1016-9040/a000039](https://doi.org/10.1027/1016-9040/a000039).
- Taris, T. W. (2000). Quality of mother-child interaction and the intergenerational transmission of sexual values: A panel study. *Journal of Genetic Psychology*, 161, 169–181.
- Taris, T. W., Semin, G. R., & Bok, I. A. (1998). The effect of quality of family interaction and intergenerational transmission of values on sexual permissiveness. *Journal of Genetic Psychology*, 159, 237–250.
- Triandis, H. C. (1995). *Individualism and collectivism*. Boulder: Westview.
- Trommsdorff, G. (2009). Intergenerational relations and cultural transmission. In U. Schönplflug (Ed.), *Cultural transmission: Psychological, developmental, social, and methodological aspects* (pp. 126–160). New York: Cambridge University Press.
- Trommsdorff, G. (2012). Cultural perspectives on values and religion in adolescent development: A conceptual overview and synthesis. In G. Trommsdorff & X. Chen (Eds.), *Values, religion, and culture in adolescent development* (pp. 3–45). New York: Cambridge University.
- Tulviste, T. & Gutman, P. (2003). A comparison of values preferences and attitudes toward collectivism of institution-reared and home reared teenagers. *European Journal of Psychology of Education*, 18(1), 33–42.
- White, F. I. (2000). Relationship of family socialization processes to adolescent moral thought. *The Journal of Social Psychology*, 140, 75–91.
- White, F. A., & Matawie, K. M. (2004). Parental morality and family processes as predictors of adolescent morality. *Journal of Child and Family Studies*, 13, 219–233. doi:[10.1023/B:JCFS.0000015709.81116.ce](https://doi.org/10.1023/B:JCFS.0000015709.81116.ce).
- Yi, C., Chang, C., & Chang, Y. (2004). The intergenerational transmission of family values: A comparison between teenagers and parents in Taiwan. *Journal of Comparative Family Studies*, 35, 523–545.
- Zhang, J., Norvilitis, J. M., & Ingersoll, T. S. (2007). Idiocentrism, allocentrism, psychological wellbeing and suicidal ideation: A cross cultural study. *Journal of Death & Dying*, 55, 131–144. doi:[10.2190/OM.55.2.c](https://doi.org/10.2190/OM.55.2.c).